

Auftragsbreite max. Application width max. [inch - mm]	Anzahl Module Quantity of modules	Abstand Module Distance of modules [mm]	Artikel-Nr. Article-No.
2 - 50,8	1	0	77.30001.701
3 - 76,2	1	0	77.30001.702
4 - 101,6	2	50,8	77.30002.701
5 - 127	2	63,5	77.30002.702
6 - 152,4	3	50,8	77.30003.701
7 - 177,8	3	59,26	77.30003.702
8 - 203,2	4	50,8	77.30004.701
9 - 228,6	4	57,15	77.30004.702
10 - 254	5	50,8	77.30005.701
11 - 279,4	5	55,88	77.30005.702
12 - 304,8	6	50,8	77.30006.701
13 - 330,2	6	55,03	77.30006.702
14 - 355,6	7	50,8	77.30007.701
15 - 381	7	54,42	77.30007.702
16 - 406,4	8	50,8	77.30008.701
17 - 431,8	8	53,97	77.30008.702
18 - 457,2	9	50,8	77.30009.701

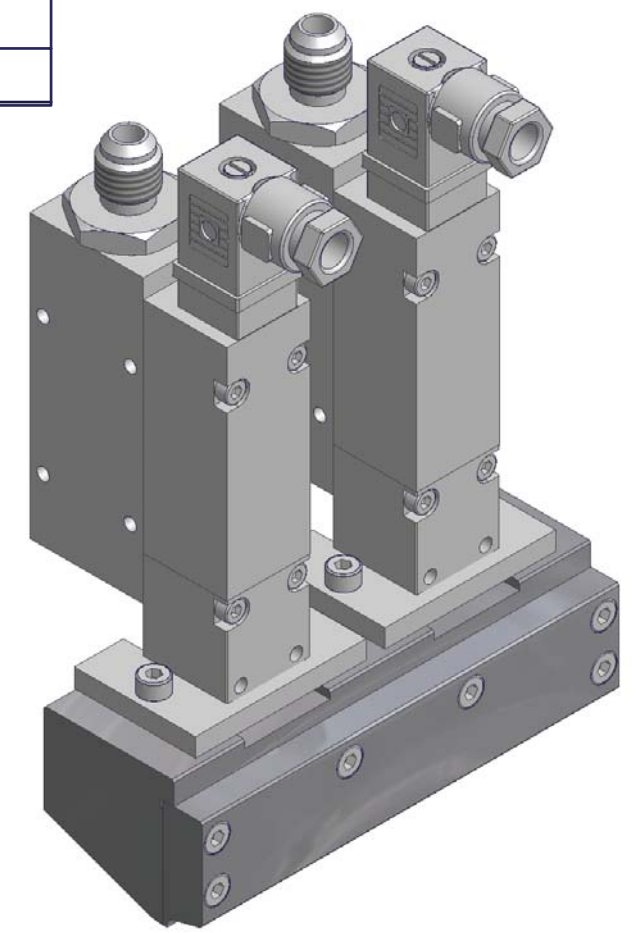

Alle Rechte vorbehalten - Copyright reserved:

	Allgemein-Toleranzen: DIN 7168 - m		Maßstab: 1:1	Werkstoff: -----
	Datum	Name	<b>Kaltleim-Flächenauftragskopf</b> Cold glue slot die head	
	Gezeichnet	08.10.02 Pahl		
	Kontrolliert			
Status	Änderungen	Datum	Name	77.3000X.70X Blatt 1 von 1