

Operating Instructions for Reka Hot-Melt Glue Gun

TR 60.3 Hot-Spray System



Table of Contents

Product Description	3
Trouble-Shooting	4
General Safety Instructions	5
Start-up	7
Operation	9
Additional Information	10
EC-Conformity Certificate	11
Exploded Views	12
Spare Parts Legend	13

Dear customer,

The glue gun you purchased will help you to glue parts together more easily and more rapidly. Before using the gun please read these instructions thoroughly.

Product Description

Proper Use

The gun works with hot glue which is dispensed under pressure. Therefore, the glue gun should only be used by qualified people. Handling the gun properly will save you unnecessary accident hazards and problems.

The TR 60.3 Hot-Spray System consists of glue gun and supply unit incl. a stand for depositing the gun when not in use. Compressed air control and manometer indication are integrated in the stand.

Personal injury or material damage caused by an improper use of the Hot-Melt System shall not be the manufacturer's but the user's responsibility.

Technical Data

Connection	230 V / 110 V
Heating capacity	400 W
Air control glue, max.	6 bars (only in combination with pressure controller. A filter must be added)
Air control spraying, max.	6 bars
Air consumption max.	100 l/min
Temperature control	electronic
Temperature control range	approx. 100 - 200°C / 200 - 390 °F (infinitely variable)
Overheat protection	temp. controller
Fuse	4 A
Heat-up time	3 - 10 min (depending on glue type)
Length supply unit (hand gun/stand)	4.5 m
Length power cable	4.0 m
Tank capacity	250 ml
Min. thickness per m	3 g
Max. application of glue per min.	250 ml
Weight hand gun	1200 g

Accessories

Foot switch art.no. 3517/3518
 Stationary equipment art.no. 3618
 Balancer art.no. 3544
 Wide spray nozzle art.no. 3538
 Funnel for granular glue art.no. 3624

By means of adapter art.no. 3522, the TR 60.3 Hot-Spray System may be modified to apply glue in lines and dots.

- **Special nozzles upon request.** Please ask for our accessory nozzle leaflet.

Trouble - Shooting

Survey on Possible Fault Signals and Assistance in Trouble-Shooting

In case of damage, send glue gun to Reka. We shall not be responsible for any repair made by the customer.

Problems	Possible Causes/ Faulty Operation	Trouble-Shooting
No or too little glue comes off though the heat-up time has been exactly observed	<ul style="list-style-type: none"> • clogged nozzle • pressure too low • temperature too low • defective valve 	<ul style="list-style-type: none"> • unscrew nozzle, clean or replace it • check controller • check temperature • replace valve
Glue is too fluid or too consistent	<ul style="list-style-type: none"> • temperature too high or too low 	<ul style="list-style-type: none"> • check temperature
Glue leaks out of nozzle	<ul style="list-style-type: none"> • sound absorber got stuck • clogged nozzle • spring pressure ball valve (nozzle) too low 	<ul style="list-style-type: none"> • clean or exchange sound absorber • unscrew nozzle, clean it carefully or replace it. Unscrew nozzle at operating temperature; wear gloves (risk of burning) • re-adjust pressure
No temperature	<ul style="list-style-type: none"> • defective fuse • instrument switched off • defective electronics 	<ul style="list-style-type: none"> • check fuse and replace it if necessary • check flip switch and switch it on if necessary (is cable properly connected to socket?) • return gun to supplier
Gun does not produce optimum spray pattern		<ul style="list-style-type: none"> • check air flow for spraying: <ul style="list-style-type: none"> - shut pressure controller for adhesive flow at stand - open air pressure controller for spraying at stand (max. 6 bars) - adjust temperature (no. 37) at gun casing to 200°C / 390 °F. - Operate trigger (no 36). After max. 30 sec., hot spray air must be dispensed. If, after this time, the spray air coming off the gun is not hot, return the instrument to your supplier.

General Safety Instructions

User's Care and Diligence

The Hot-Spray Glue Gun has been designed and fabricated according to the applicable harmonized standards and further technical specifications. So, it is state of art and ensures a maximum of safety. This safety, however, can only be achieved in practice, if all necessary measures have been taken. The user of the device shall be obliged to plan these measures and to make sure that they are taken.

In particular, the user shall ensure that

- the gun is in working order
- the required personal protective equipment (protective gloves) for the operating personnel is available and used
- the entire operating instructions are in legible condition and available to the operator
- only sufficiently qualified and authorized personnel operates and maintains the gun
- this personnel is regularly instructed in the applicable aspects of operational safety and environmental protection, and knows the operating instructions and, in particular, the safety instructions.

Make the information available:

This operating manual shall be kept on the site of operation. It must be ensured that all persons operating the gun can look into the manual at any time. In addition to the operating manual, the instructions pursuant to the Factory Act and the regulations as regards the use of equipment shall always be at the operator's disposal.

Meaning of the Various Safety Symbols

This operating manual shall give concrete advice as to safety to draw the user's attention to remaining unavoidable hazards. These hazards imply dangers to

- persons
- product and equipment

The symbols used in the operation manual shall, in particular, call attention to the safety instructions!

This symbol indicates that there is, above all, danger to persons, but also to equipment and material.



Caution: Hot surface!

Accident Prevention Regulations VBG 125 - W26

Hot surfaces such as machine parts, tanks or materials, but also hot liquids cannot always be perceived. The utmost caution is advised when this symbol is attached to a component.

Always wear protective gloves when you have to touch hot surfaces.

Safety Measures in Case of Normal Operation

The instrument must only be used by persons trained and instructed and being allowed to use it. They have to know the operating instructions and be able to work accordingly.

Prior to each use, check the gun for visible damage and make sure that it is in perfect condition! Advise detected defects to your superior at once!



Safety Instructions for the Use of Holt-Melt System TR 60.3

- **Fill tank only up to 1.5 cm below upper rim.**
- Never exceed operating temperature.
Overheating may lead to decomposition which may affect health.
- **Once the gun has warmed up, nozzle and cover are extremely hot.**
- Compressed air pressure max. 6 bars.
- Never start working without having mounted a nozzle.
- **Do not direct glue jet towards people.**
- Prior to any nozzle replacement, unplug connecting cable.
- When replacing a nozzle, liquid glue might leak out. **Warning: Risk of burning!**
- Never bring the hot nozzle into contact with the cable.
- **When your skin got into contact with hot glue, immediately cool it with cold water. Do not try to remove hot melt from the skin first. If necessary consult your doctor.**
- **When hot adhesive got into your eyes, immediately cool them under running water for about 15 minutes and consult your doctor at once.**
- If the vent valve does not audibly de-aerate, hot glue might flow off the sound absorber after the trigger has been operated.
- **Always wear protective gloves!**

Note:

- Do not lay gun on its side
- Fill tank only up to max. 1.5 cm below upper rim
- Gun must de-aerate audibly
- Always de-aerate before lid is opened
- Do not direct glue jet towards people
- Do not hold nozzle top upwards
- Never work without having mounted a nozzle
- Do not carry out overhead work
- Stop using the instrument, if casing is damaged due to shock, breakage or heavy wear

- Even if the gun has been switched off, it may be under pressure and glue may flow off.
- **When using the stand, remove wire strap**

Start-up and Operation

To avoid risk of stumbling:

Lay all instrument connections (cables, hoses, and lines) so that they do not cause any risk of stumbling (cable conduits, bridges)!

Make supply connections and settings

Connect the TR 60.3 Hot-Spray System to the electric mains of 230 V / 110 V and a compressed air line of max. 6 bars.

- Plug connecting cable into socket with earthing contact.
- Switch on glue gun by operating the flip switch (no. 32) at the gun casing. Lamps signalling readiness for operation (nos. 38 + 39) will then emit light
 - green = connection to mains
 - red = heating
- Adjust working temperature for hot melt (no. 37). Minor leaking during heat-up phase is due to hot melt expanding in the nozzle/heating chamber.
As soon as the working temperature is reached, the hot melt will not leak out anymore.

**Warning: Once the gun has warmed up, nozzle and cover are extremely hot!
Never work without wearing protective gloves!**

Stand

When the stand is used as a deposit, do not fit the wire strap to the gun!

- Connect compressed air hose to the rear side of the stand.
- Pressure controller right = air for spraying 1 - 2 bars*
Pressure controller left = air for glueing 2 - 4 bars*

*** Depending on glue type and quantity to be applied**

Loading of Glue

- As soon as the gun has warmed up, open cover (no. 11) by turning the star grip (no. 18) to the left. Load selected glue.
- Fill tank only up to approx. 1.5 cm below upper rim. To close the cover turn grip to the right.
- Allow approx. 3 - 10 minutes, depending on quantity and type of glue, for the instrument to melt the glue. The quantity to be applied can be determined by pressing the trigger (no. 36); the longer you press, the more glue comes out.

Application of Hot Melts

Make yourself familiar with the instrument first. Apply a little glue in varying forms (small, large spray dots) on a piece of paper or cardboard. This is very easy. Try to find out the correct quantity and the ideal spray pattern by adjusting the pressure controllers at the stand to different pressures.

Observe the correct working temperatures of the individual hot melt.

Never start working without having mounted a nozzle!

Spraying of Pressure-Sensitive Hot Melts

The supplied Hot-Spray System is designed for spraying pressure-sensitive hot melts. Nevertheless, check whether the complete spray head (drawing detail „C“) is attached to the gun; if this is not the case, attach it. Screw spray cap (no. 25) slightly by hand. Do not use any pliers or the like.

You are advised to wear protective gloves.



Do not direct glue jet towards people!

Application of Hot Melts in Lines and Dots

By attaching the respective nozzle adapter the glue gun may be modified to apply glue in dots and/or lines. For this, it is necessary to exchange the complete spray head. For the correct nozzle assembly see encl. drawing „Nozzle Assembly for Caterpillar-Type/Point-by-Point Application“. For this, the controller for spray air must be shut.

Nozzle Replacement

Only replace nozzles when the glue gun is warm (instrument temperature 60 - 80°C / approx. 140 - 175 °F) and empty. For the replacement you need a SW 13 open-end spanner. You are advised to wear gloves.



Prior to exchanging nozzles, unplug connecting cable!

Replacing a cold nozzle may damage the gun. If the nozzle is replaced when it is too hot, liquid adhesive may leak out.



Warning: Risk of burning!

- When your skin got into contact with hot glue, immediately cool it with cold water.
- Do not try to remove hot melt from the skin first. If necessary consult your doctor.
- When hot adhesive got in your eyes, immediately cool them under running water for about 15 minutes.

Consult your doctor at once!

Never start working without having mounted a nozzle!

Do not direct glue jet towards people!

Working with Stationary Equipment

(in connection with pneumatic foot switch)

To work with stationary equipment mount glue gun and foot switch according to enclosed drawings „Connection of Foot Switch“ and „Stationary Equipment“. Then, proceed as follows:

- Press trigger (no.36) down to stop and hold it
- Plug enclosed screw into the borehole provided for this purpose at one side of the casing handle
- Let trigger loose
- Trigger is locked

Operation

The glue gun shall only be used/applied according to its intended use. Please see Section "General Safety Instructions".

Improper use of the gun may cause personal injury or material damage.

Non-observance of the safety instructions when working with the gun may lead to serious burns.

Make a functional test acc. to the following list, before you switch on the glue gun:

Check List

- Did you make sure that compressed air is supplied to the glue gun?
- Is pressure max. 6 bars and min. 2 bars?
- Is the glue gun connected to 230 volts / 110 volts and the flip switch switched on?
- Do lamps signalling readiness for operation emit light?
- Is the nozzle clean and free of any foreign matters?
- Is hot melt in the premelting tank?
- Has the heat-up time of approx. 10 minutes (depending on the glue type) been observed?

While you are working...

...the glue gun always has to be deposited on its stand (unless it is fitted to a balancer).

Never lay gun on its side!

- Open premelting tank only if required.
- Keep hot melt free of dirt and humidity.

When using the stand, remove wire strap!

General Hints

Should the sound absorber (no. 6) get stuck, the adhesive tank may be under pressure. **The vent valve (sound absorber) must audibly de-aerate each time you operate the trigger (no. 36).**



Warning: With this, hot glue might come off the sound absorber!

If the vent valve does not de-aerate audibly, the adhesive tank must be de-aerated by unscrewing the sound absorber (no. 6), the DT - SEV (no. 7) and the swivelling screw (no. 44).

For this, you are advised to wear gloves.

No liquid glue should get into the sound absorber, when the gun is ready for operation.

Always deposit the gun on its stand or use the wire strap or a balancer. **When using the stand, remove wire strap!**

If nevertheless, glue should have got into the vent valve, either clean that valve or replace sound absorber, DT - SEV and swivelling screw.

Never fill the premelting tank up to its upper rim.

- Note:**
- Do not lay gun on its side
 - Never overcharge instrument; max. 1.5 cm below upper rim
 - Instrument must de-aerate audibly
 - De-aerate before lid is opened
 - Do not direct glue jet towards people
 - Do not hold nozzle top upwards
 - Never work without having mounted a nozzle
 - Do not carry out overhead work
 - Stop using the instrument, if casing is damaged due to shock, breakage or heavy wear.

Even if the gun has been switched off, it may be under pressure and glue might flow out!
When using the stand, remove wire strap!

Cleaning and Maintenance

Only fill clean glue into the premelting tank. Contaminated glue, nails, clamps, sand, etc. cause malfunctions. If you observe the operating instructions, the gun does normally not need cleaning. The glue remaining in the gun will remelt when it is warmed up and can be used for glueing again. The glue must not get too hot, otherwise it may coke (hot melts on a polyamide basis are particularly sensitive). If this has happened, the gun should be cleaned with REKA cleaning liquid.

If the gun is used very often, it has to be maintained regularly. To set a date, please call our service department.

Additional Information

Do you have any more questions or requests? We should be glad to help you.

Please contact us at phone no. ++49-721-970 780 or fax no. ++49-721-705 069

Our mailing address is:

Reka Klebetechnik GmbH & Co. KG.
Siemensstr. 6

D - 76344 Eggenstein
Germany

e-mail: info@reka-klebetechnik.de

Internet: www.reka-klebetechnik.de

CE EC-Conformity Certificate

The Manufacturer:

Reka Klebetechnik GmbH & Co. KG,
Siemensstr.6 D-76344 Eggenstein

certifies that the design of the:

TR 60.3 Hot-Spray System

is in conformity with the regulations of EC
Guidelines:

73/23/EEC 89/392/EEC revised
91/368 EEC 89/336 EEC

The following harmonized standards have been applied:

EN 60335 EN 292 EN 60204 HD 400 EN 55014 EN 60555 EN 61000

Design modifications influencing the technical data specified in the operating manual and the intended use, thus meaning a considerable change of the device, render this conformity certificate invalid!

There exists a complete technical documentation.

An original version of the operating instructions for the glue gun, in the national language of the user – here English -, is enclosed.

Eggenstein, January 1st, 1996

Signature

Karl Coenen / Product Manager

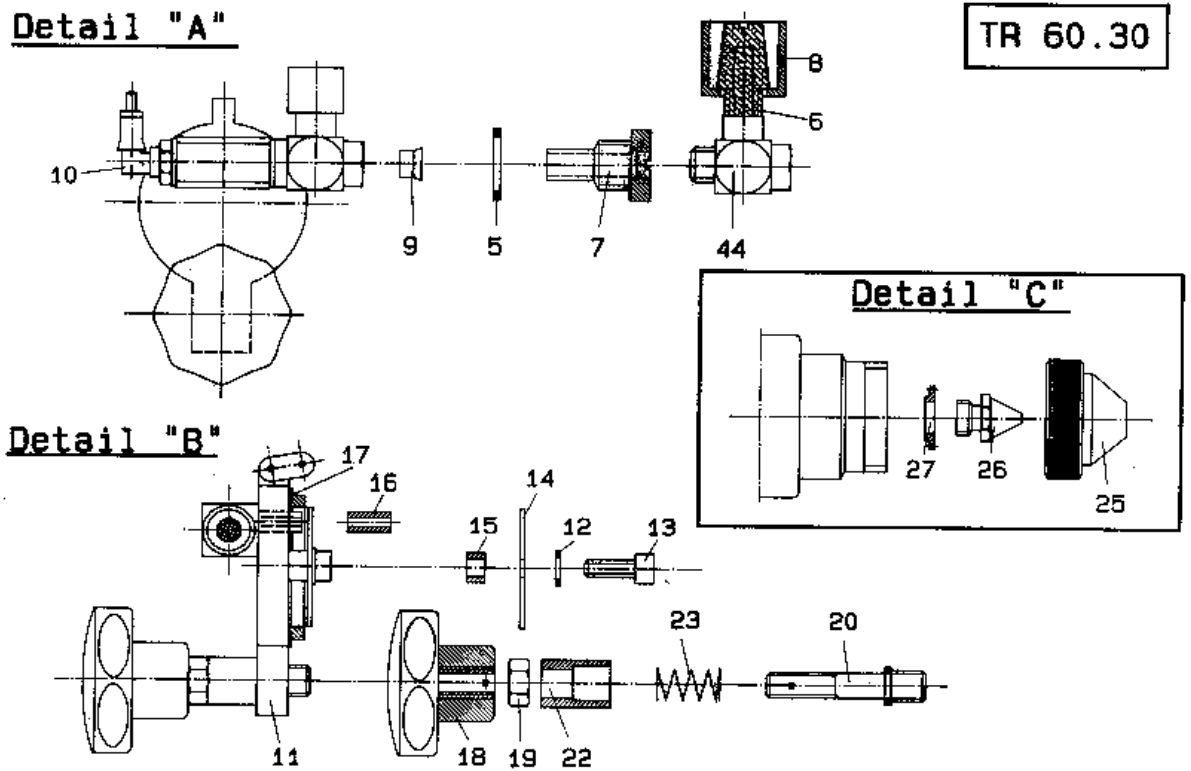
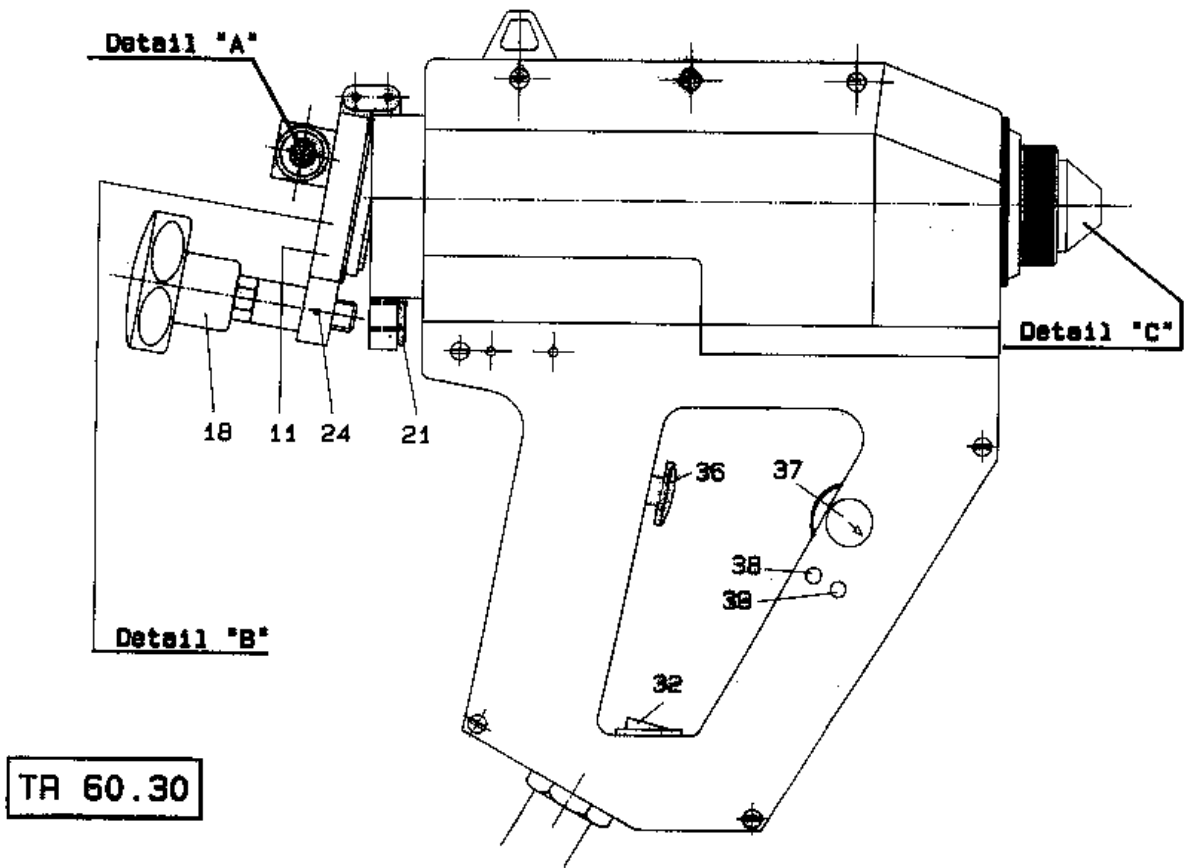

Legend for spare parts - Hot-Spray-System TR-60.30 – No. 5324 - 220 V

5 =	2692	O-Ring SEV
6 =	2683	Sound absorber
7 =	2693	DT SEV D 16
8 =	2694	Cap SEV D 18
9 =	2696	Membrane SEV
10 =	2697	90° fitting SEV
11 =	2713	Lid
12 =	2800	Disc
13 =	2801	Screw
14 =	2819	Sheet
15 =	2802	Intensification
16 =	2820	Distance
17 =	2603	O-Ring 40x3
18 =	2613	Star grip
19 =	3665	Lock nut
20 =	2883	Lid release shaft M8-Tr 10x3
21 =	2884	Lock nut for lid release Tr 10x3
22 =	2885	Spacer bush D1.4120
23 =	2718	Spring
24 =	2911	Safety screw
25 =	3057	Spray cap
26 =	3051	Spray nozzle cpl.
27 =	2606	Spacer
32 =	2918	Switch on/off
36 =	2711	Trigger
37 =	3666	Temperature regulator
38 =	2934	Control bulb (mains)
39 =	2973	Control bulb (heater)
44 =	3016	L-Screwing

